

BRISTAN

TAPS & SHOWERS

Installation Instructions & User Guide

Please leave these instructions with the end user

Product code: PS2 1/2 C (D2)

Specifications

Dynamic Water Pressure (bar)

Min: 0.3

Max: 5.0

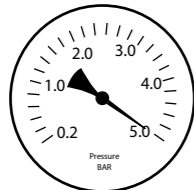
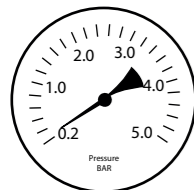

Maximum Static Pressure: 10.0

Inlet water temperature

Cold Water Supply

Hot Water Supply

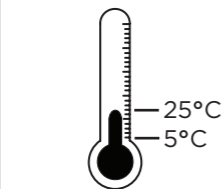

Min: 5°C Max: 25°C

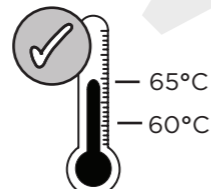

60-65°C recommended

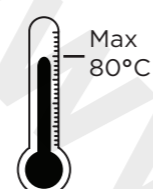

80°C Maximum

Inlet Connections

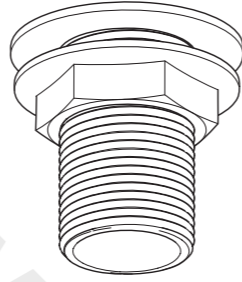

1/2" Male BSP Tap connector

Tools you'll need

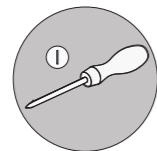

Flat Screw Driver



Adjustable Spanner

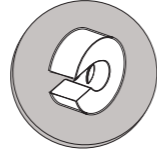

Pipe Cutter

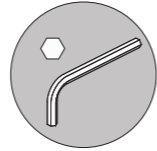

Hexagonal Keys

Prior to Installation

All products manufactured and supplied by Bristan are safe provided they are installed, used correctly and receive regular maintenance in accordance with these instructions.

This product has been tested to the Water Regulations Advisory Scheme (WRAS) and satisfies the requirements of the Water Supply (Water Fittings) Regulations 1999 and current bylaws.

For full Installation Requirements & Notes (IRN) please visit: www.wras.co.uk/directory

Isolation valves must be fitted to the inlet water supplies to ensure ease of future maintenance.

Before installing these taps the water supply must be thoroughly flushed in order to remove any swarf, solder etc from the pipework.

Pack Contents

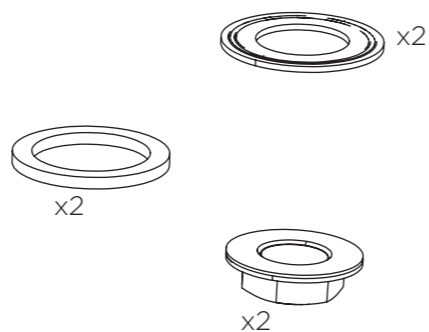
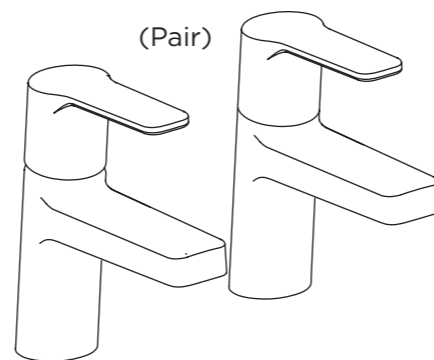

Installation

1

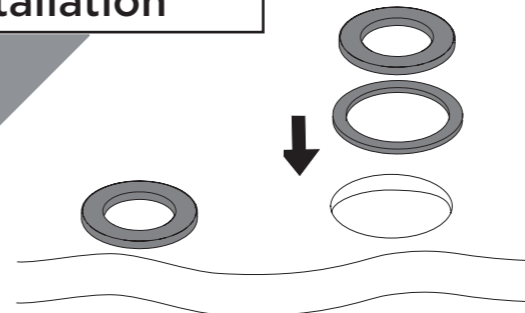

Place the plinths over the holes in the basin ensuring that the washers are fitted between the plinths and the basin.

2

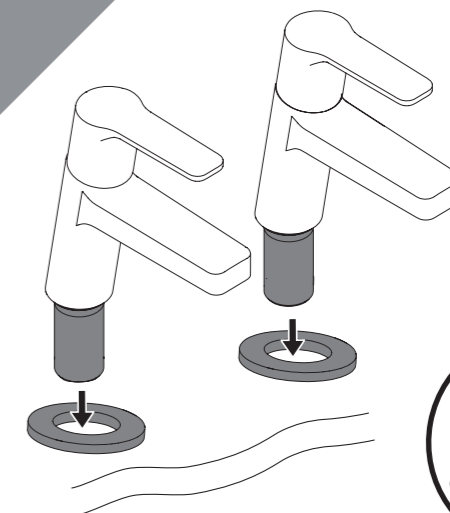

Fit the taps to the basin.

Tip
remember
hot on the
left, cold
on the right

3

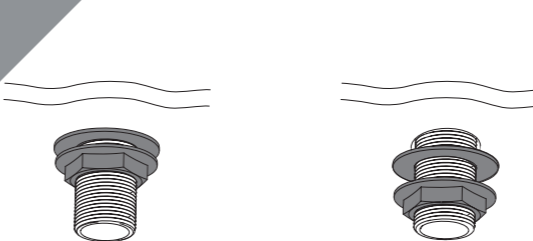

Secure the taps to the basin by using the washer and metal backnut below the basin.



Tighten the backnut onto the threaded tails.

4

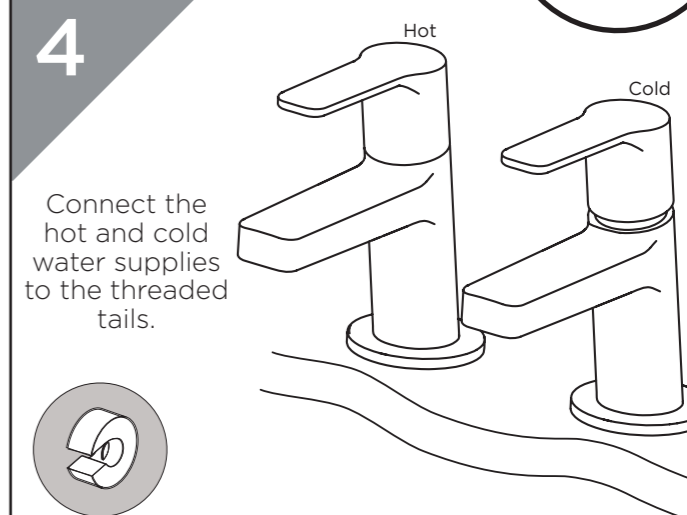

Connect the hot and cold water supplies to the threaded tails.

5

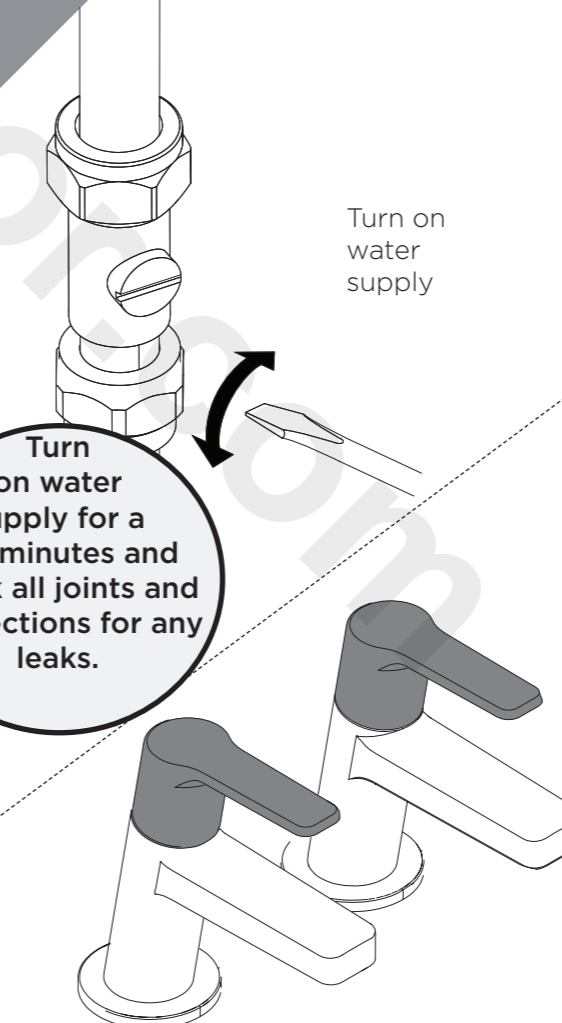

Turn on water supply

Turn on water supply for a few minutes and check all joints and connections for any leaks.

Operation

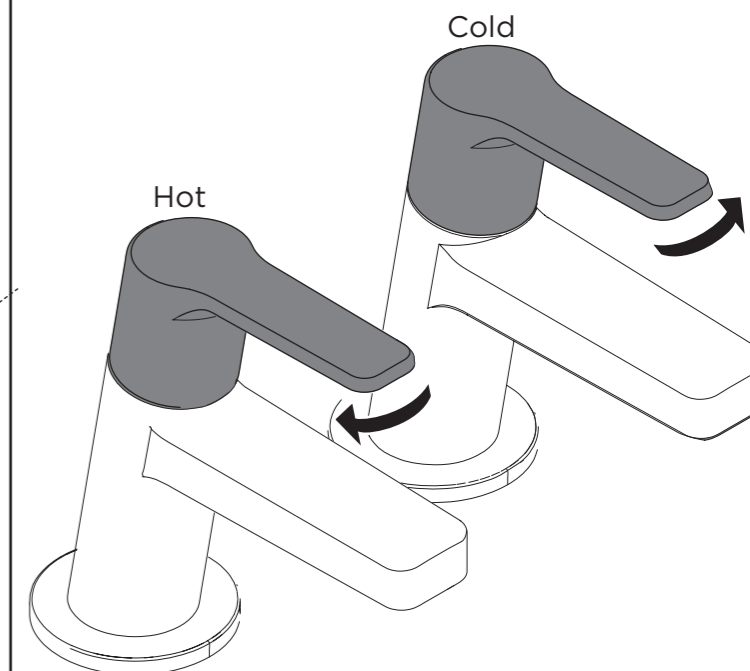

Move the hot lever left and the cold lever right to increase the flow of water

Maintenance - Ceramic Valve Cleaning

1

2

3

4

5

Spares

To replace any spare parts for your basin taps why not scan the QR code and search for your product

Maintenance - Flow Straightener

1

2

Servicing Your Tap

We recommend servicing your tap at least once every year to prolong its life. To see a video showing how to remove the cartridge for servicing, scan the QR code with your smart phone or tablet.

Alternatively visit www.youtube.com/bristantv

General Cleaning

Your fitting has a high quality finish and should be treated with care to preserve the visible surfaces.

All surfaces will wear if not cleaned correctly, the only safe way to clean your mixer tap is to wipe with a soft damp cloth. Stains can be removed using washing up liquid. All bath cleaning powders and liquids will damage the surface of your fitting, even the non-scratch cleaners.

Note: Never use abrasive detergents or disinfectants or those containing alcohol, hydrochloric acid or phosphoric acid.

Troubleshooting

Symptom	Cause	Remedy
No flow or low flow rate	partially closed isolation valve.	Open isolation valve.
	Instantaneous water heater cycles on and off as flow rate or pressure is too low.	Increase water flow rate or pressure through system.
	Head of water is below the minimum distance required.	2 meters minimum required.
	Hot or cold water being drawn off elsewhere causing pressure changes or instantaneous boiler temperature changes.	Do not use other water outlets when using the taps.
Water dripping from taps	Airlock or partial blockage in the supply pipework.	Flush through pipework to ensure removal of debris and any airlocks.
	This is normal for a short time after using the taps.	This is caused by capillary action, the build up of water in the tap body.
Taps do not turn on	If water continues to drip, possibly due to the ceramic disc valves	Remove valves and clean, refer to 'Maintenance' section before starting any maintenance.
	Closed isolation valve.	Open isolation valve.
	Mains water supply turned off.	Turn on mains water supply.

Notes

Please use this space for any notes you or your installer may have regarding the installation / plumbing of this product.

At Bristan, we want to make things as easy as possible for our customers. That's why we offer solid guarantees on all our products, effective from the date of purchase, to give you peace of mind.

To start your free **guarantee** simply scan the QR code and register your product. Alternatively visit www.bristan.com/register to register your product via a computer.

For full guarantee terms and conditions visit www.bristan.com/guarantees.

We Know & We Care

